

//ADA STRA

Azure Native Integration PaaS





Outline

Adastra Overview

Azure iPaaS Overview

Azure iPaaS Patterns

Azure iPaaS Best Practices

Azure iPaaS Adastra Example

Azure iPaaS Roadmap

Azure iPaaS Demo



Adastra Overview



Adastra delivers industry leading **Solutions and Services** across the **Data & Digital** spectrum

DATA

- Cloud
- Data Engineering
- CRM & ERP
- Architecture
- Managed Services

GOVERNANCE

- Data Governance
- Data Quality
- Master Data Mgmt
- Reference Data Mgmt
- Meta Data Mgmt
- Data Lineage

ANALYTICS & AI

- Machine Learning
- Statistical Analysis
- Text Mining
- Visual Analytics
- RPA & IPA

DIGITAL & DESIGN

- Mobile Apps & Web Development
- UX/UI
- Personalized Videos
- Emerging Technologies



Adastra Global Footprint

2000+

2000+ professionals

1000+

Projects in 46 countries

1

Focus

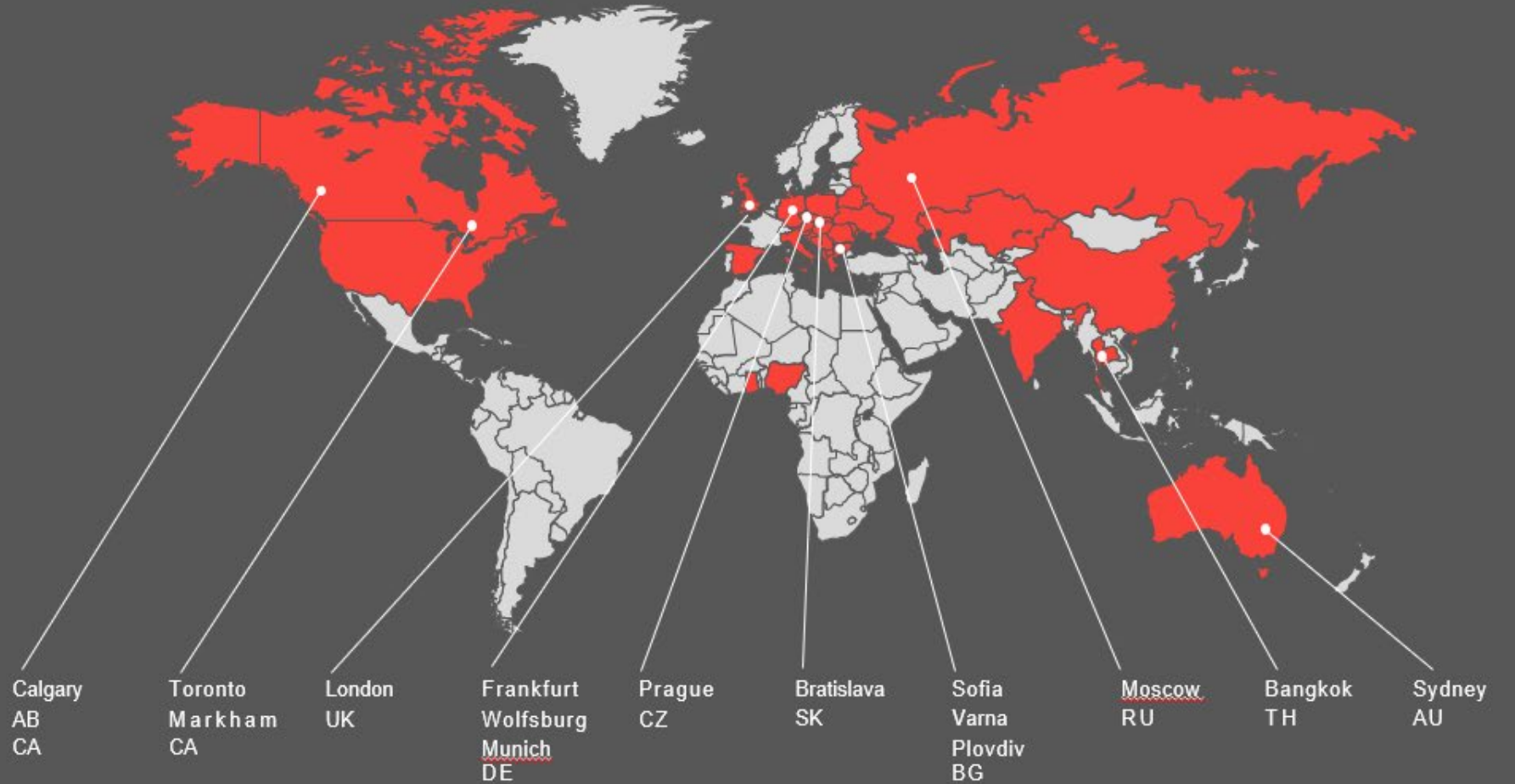



Adastra Success Stories

Adastra has successfully architected / implemented Azure Modernization solutions for > 65 organizations in the last 24 months. Select clients:



Next Done Now.™





Adastra: #1 Data / AI Partner in Canada

Microsoft Canada ranks Adastra as their #1 Data / AI Partner

2020 / 2019 Commercial Enterprise Partner of the Year, 2019 Manufacturing Innovation Impact Award



ABILITY TO SCALE

With >2000 GLOBAL staff, >500 CDN staff, and >250 Azure specialists, Adastra is ready to scale



COMPLETE STACK DELIVERY

Azure Infrastructure, Azure AppDev, Azure BizApps (O365 / D365), Azure BI Analytics, Azure Big Data, Azure Data Science, and Power Platform



PROVEN SUCCESS

Adastra has the best record in Canada, driving customer Azure adoption and customer Azure ROI, for Azure modernization



AGILE AND RESPONSIVE

Adastra's agility enables us to react / deliver for SMB customers, while also having breadth / depth for Enterprise customers



BESTSHORE DELIVERY

Adastra's bestshore delivery model ensures top global experts can be applied to any project, provides offshore economies of scale for heavy lift tasks, with global teams working in partnership with our on location experts. Adastra offers global 24 / 7 delivery and support, through our NA, EUR, and ASIA teams.



Adastra Microsoft Partnership

- ✓ **Microsoft IMPACT Award Recipient:**
 - ✓ 2020 / 2019 Commercial Partner of the Year
 - ✓ 2019 Manufacturing Innovation Award

- ✓ **Azure Gold Partner Status for:**
 - ✓ Data Analytics
 - ✓ Data Platform
 - ✓ Data Migration
 - ✓ Cloud Platform
 - ✓ Application Integration

- ✓ **Azure Migration Partner**

- ✓ **Advanced Specialization for Windows / SQL Server Migration to Azure**

- ✓ **Lead Canadian Partner for Synapse Migration / Implementation**

- ✓ **Product Team Collaboration for Azure Synapse / Azure Purview / Azure Databricks**



Adastra Azure Specializations

AZURE FOUNDATION

cloud assessment, tenant design, resource naming, service tag approach, network architecture, governance design, tco analysis, hybrid network implementation, devops integration, azure foundation implementation, ...

AZURE APP / MIGRATION

app / data assessment, app / data decisioning (lift / shift vs modernize), app / data architecture, api architecture, microservices architecture, app / data security design, migration roadmap, migration execution, iac pipelines, devops integration, ...

AZURE SECURITY

security assessment, identity strategy, role based access, secrets management, encryption, data loss protection, api management, private zone configuration, siem / soar integration, policy enforcement, security implementation ...

AZURE ANALYTICS

analytics assessment, analytics architecture, analytics roadmap, data zoning, enterprise model design (kimball, inmon, data vault), ETL data pipelines, persona enablement, citizen report development, trusted data as a service, ...

AZURE BIG DATA

big data assessment, data lake design, Hadoop integration, PySpark data engineering, ELT pipelines, spark delta lake, spark streaming, serverless compute, devops integration, ...

AZURE AI / ML

advanced analytics assessment, cognitive service integration, r&d model training / testing, mlops implementation, ai / ml pipelines, data science workbench automation, devops integration, ...

POWER PLATFORM

citizen development assessment, power platform governance, roles / responsibilities, environment strategy, CoE kit, canvas / model apps, power automate flows, power automate rpa, power platform dataverse, power bi datasets / reports, ...

AZURE DATA GOVERNANCE

data governance assessment, data catalog, data classification, data sensitivity, data use governance, data privacy, data lineage, master data management, data quality management, reference data management

AZURE INTEGRATION PAAS

integration paas assessment, api management, logic workflows, service bus management, event grid distribution, peer to peer patterns, pubsub patterns, managed file transfers, iot telemetry streaming, iot edge device



Adastra Managed Services





Adastra Azure iPaaS Solutions

IoT

(streamed telemetry)

- Husky
- Magna
- Bruce Power
- BMO
- TD
- Volkswagen
- Alectra
- Avcorp
- Woodbridge Foam Corp
- Just Energy
- Teck Resources

Event

(message payloads)

- Fleet Complete
- Bruce Power
- Just Energy
- Alectra
- Woodbridge Foam Corp
- Magna
- Matrix Solutions
- Region of Peel
- Loblaws
- Order Dynamics
- Teck Resources
- Canada Cartage
- Curbside Kitchen



Azure iPaaS Overview



- ✓ Connecting applications located anywhere within your organization
- ✓ Connecting applications inside your organization with a business partner
- ✓ Connecting applications inside your organization with a SaaS application
- ✓ Integrating applications with IoT devices

NOTE: Azure iPaaS focuses on exchanging event information between applications / devices, near real time, vs exchanging datasets by batch (i.e. use Azure Data Factory for ETL / ELT instead).



Azure iPaaS Use Cases

Use Case	Azure iPaaS
A2A	✓
B2B	✓
EDI	✓
IoT	✓



Azure iPaaS Services

Four Azure services work together to deliver Azure Integration PaaS.

Azure Integration PaaS handles JSON / XML / FILE communication between applications / IoT. It is only one of the patterns for IoT ingestion, but the primary pattern for application integration.

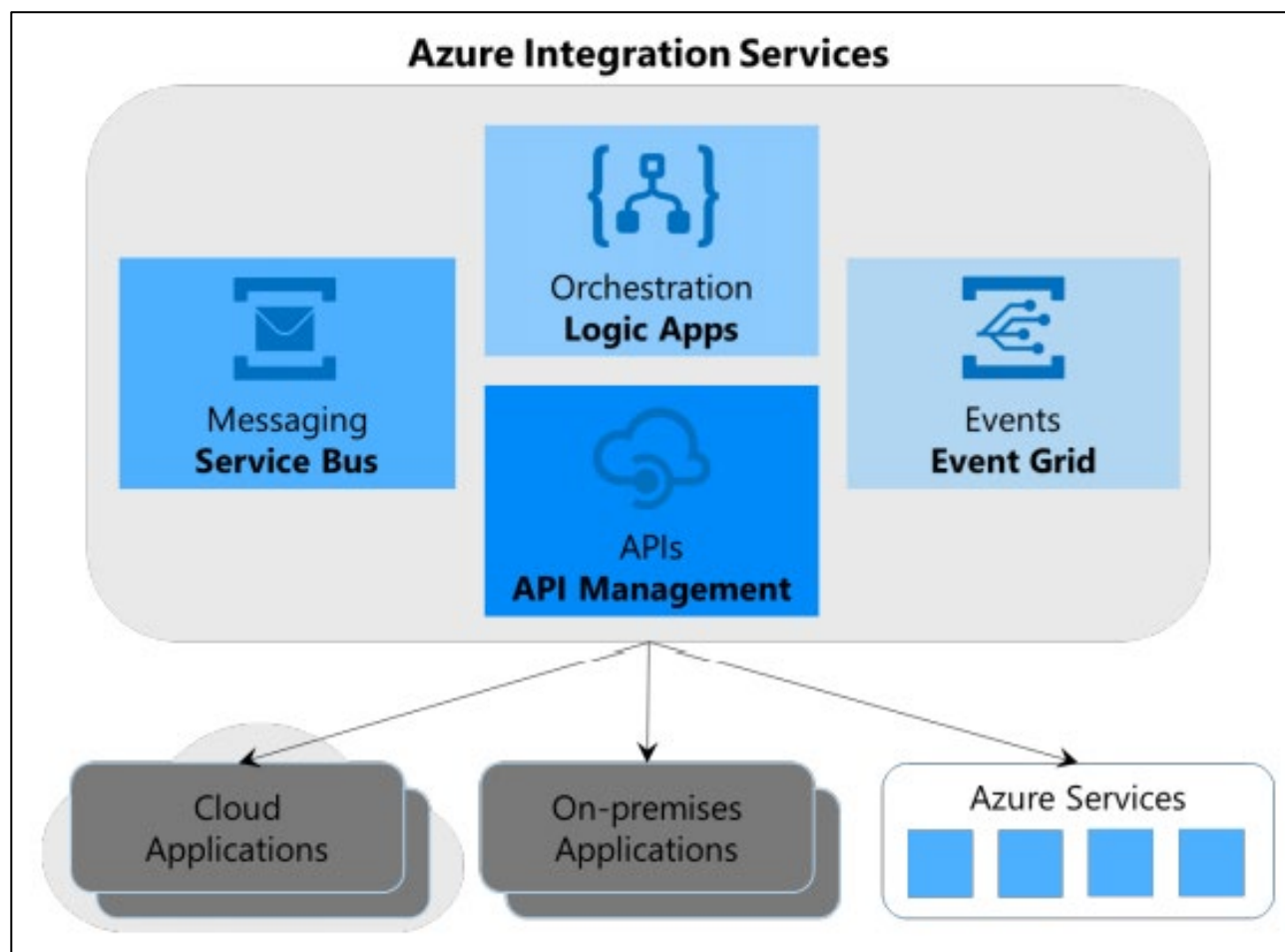



Azure iPaaS Benefits

**Services Implement
in Minutes**

Unlimited Scale

Pay for Use Pricing

**>100 Connectors
Supported**

**Fully Integrated
Platform as a Service**

**Azure Governance
Ecosystem**

Reduces TCO by 50%

**Realize App Integrations
2X Faster**

**No Code
Development**



Azure API Management

To effectively manage Azure iPaaS, a robust API management capability is needed.

- Control the number of API calls allowed.
- Monitor API activity.
- Require API authentication.
- Analyze API trends.
- Manage performance thru caching.
- Facilitate API use by developers.

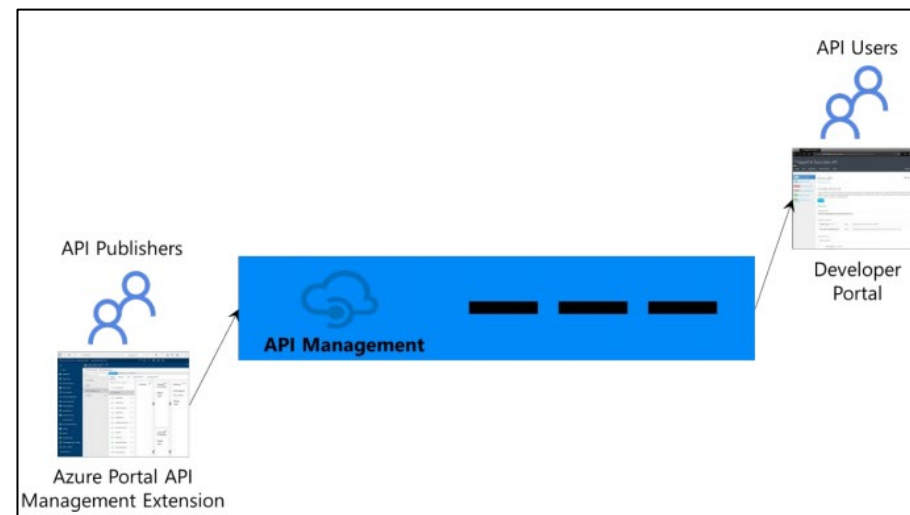
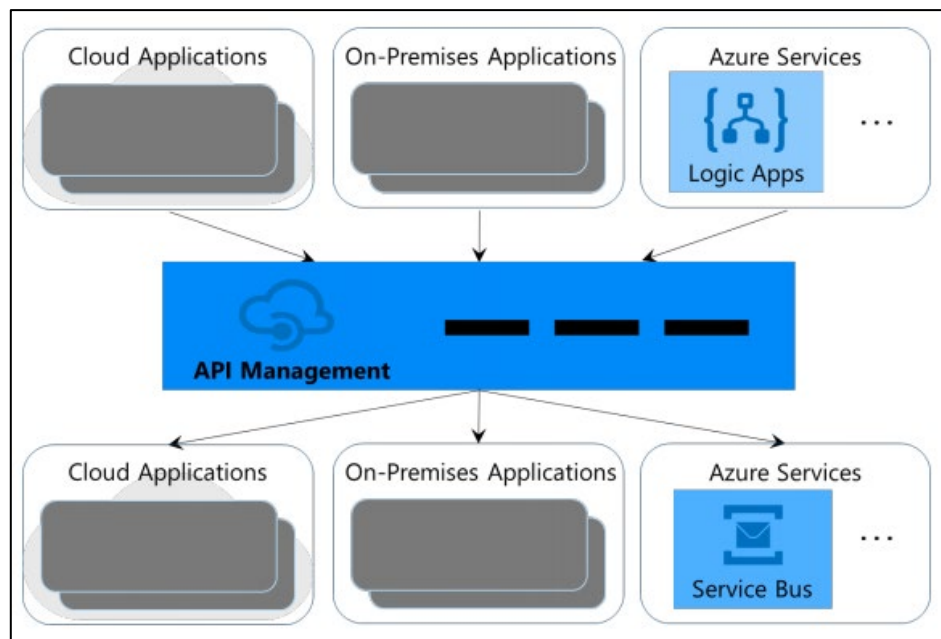



Azure Logic Apps

Azure Logic Apps provide a no code workflow engine to orchestrate the flow of data and actions.

- Monitor an FTP site for a new file and trigger a notification and file transfer when the file appears.
- Respond to a JSON file received via an API by performing a lookup to add data then sink to a service bus
- Acquire a JSON file from a service bus, transform to an XML file, then send to a target application API

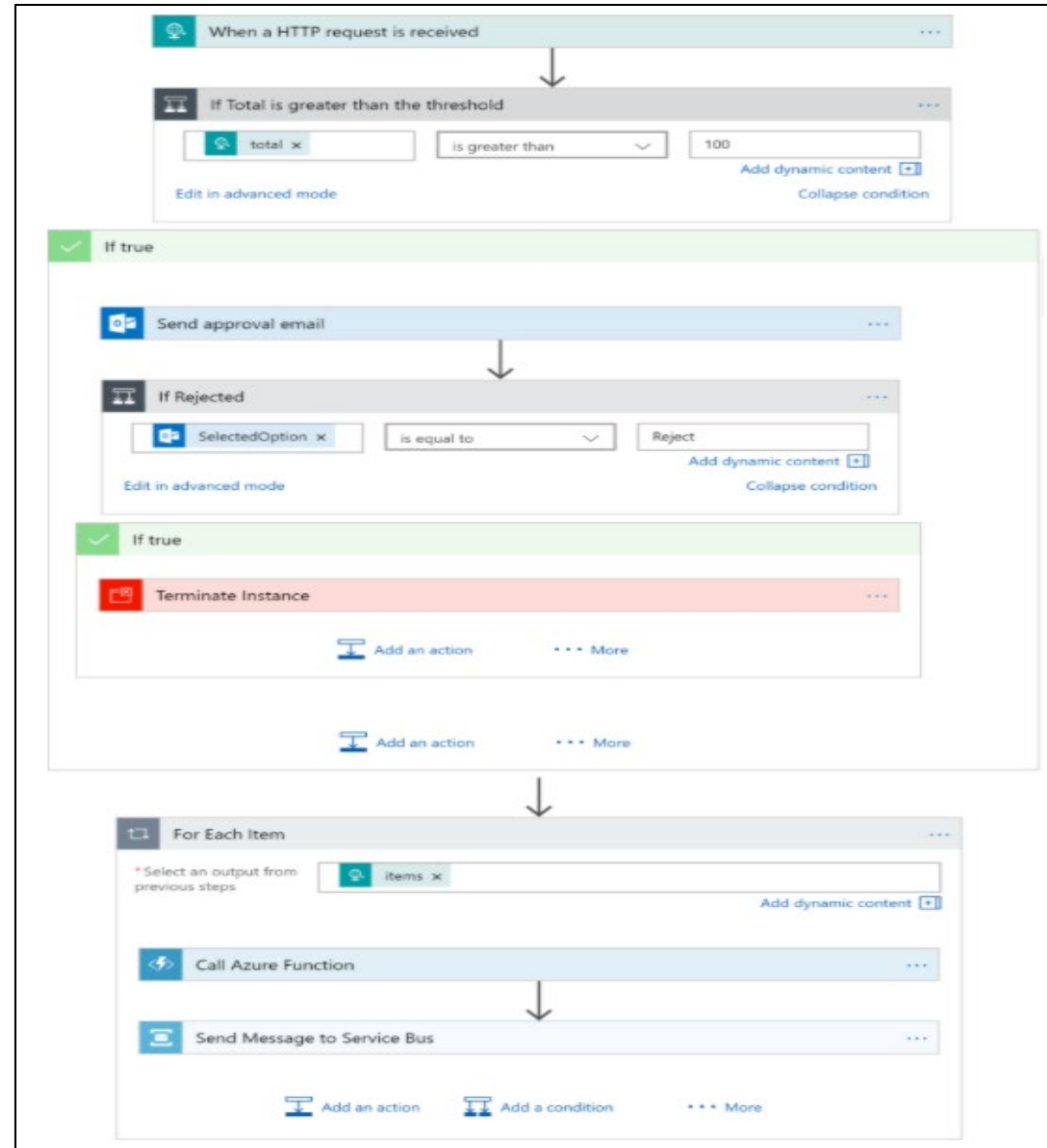



Azure Logic Apps EIP

The Azure Logic Apps Enterprise Integration Pack facilitates seamless communication between organizations using standard EDI format.

Supports industry standard protocols AS2 / X12 / EDIFACT / ...

Supports Electronic Data Interchange / Enterprise Application Integration standards.

Supports SAP / IBM / ... (50+ connectors).

Stores artifacts (partners, agreements, schemas, maps, certs) centrally in an Azure integration account.

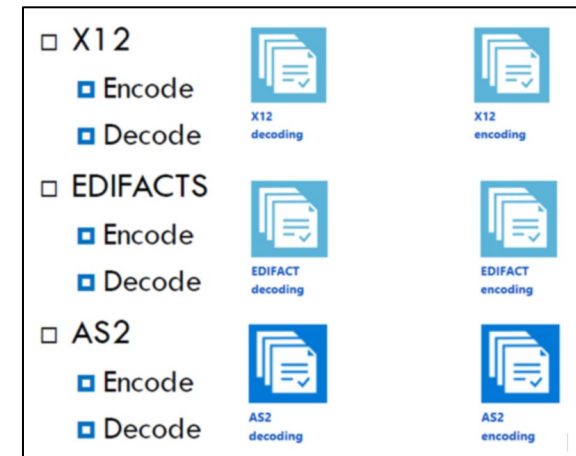
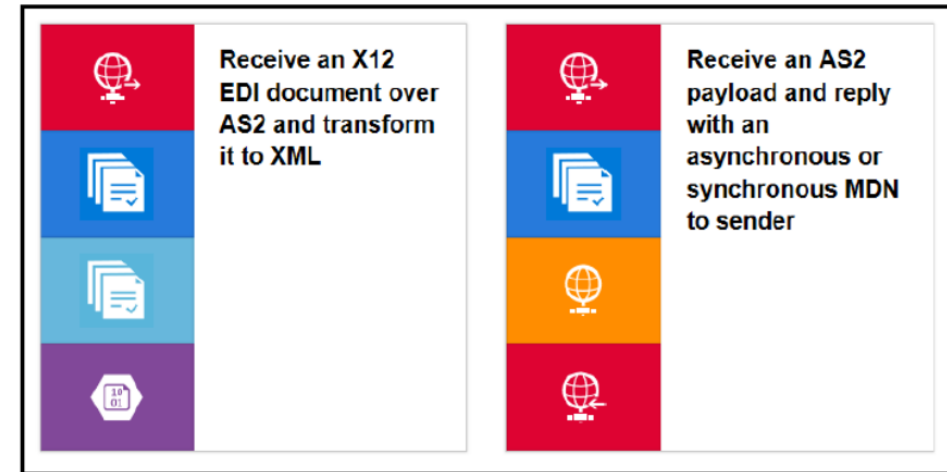
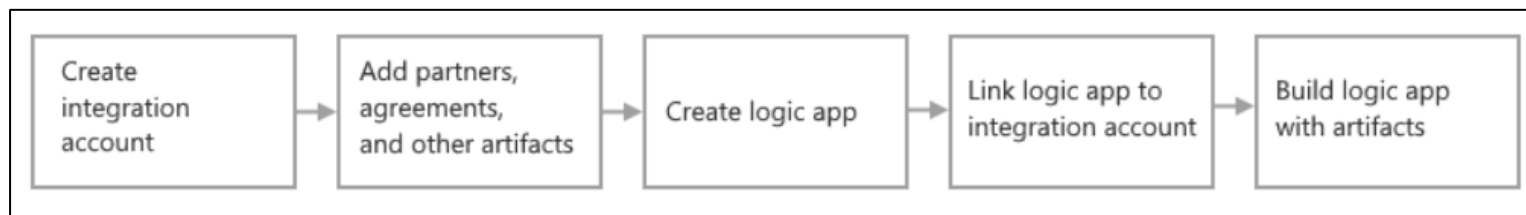



Azure Service Bus

Azure Service Bus facilitates async communication between applications, enabling guaranteed message delivery.

- Queue management (first in / first out, ...).
- Detect / delete duplicate message capability.
- Atomic transactions (queue events part of whole)
- Poison message handling (manage bad messages)
- Exception handling / retry controls
- Dead letter queue
- High availability / geo-replication / disaster recovery

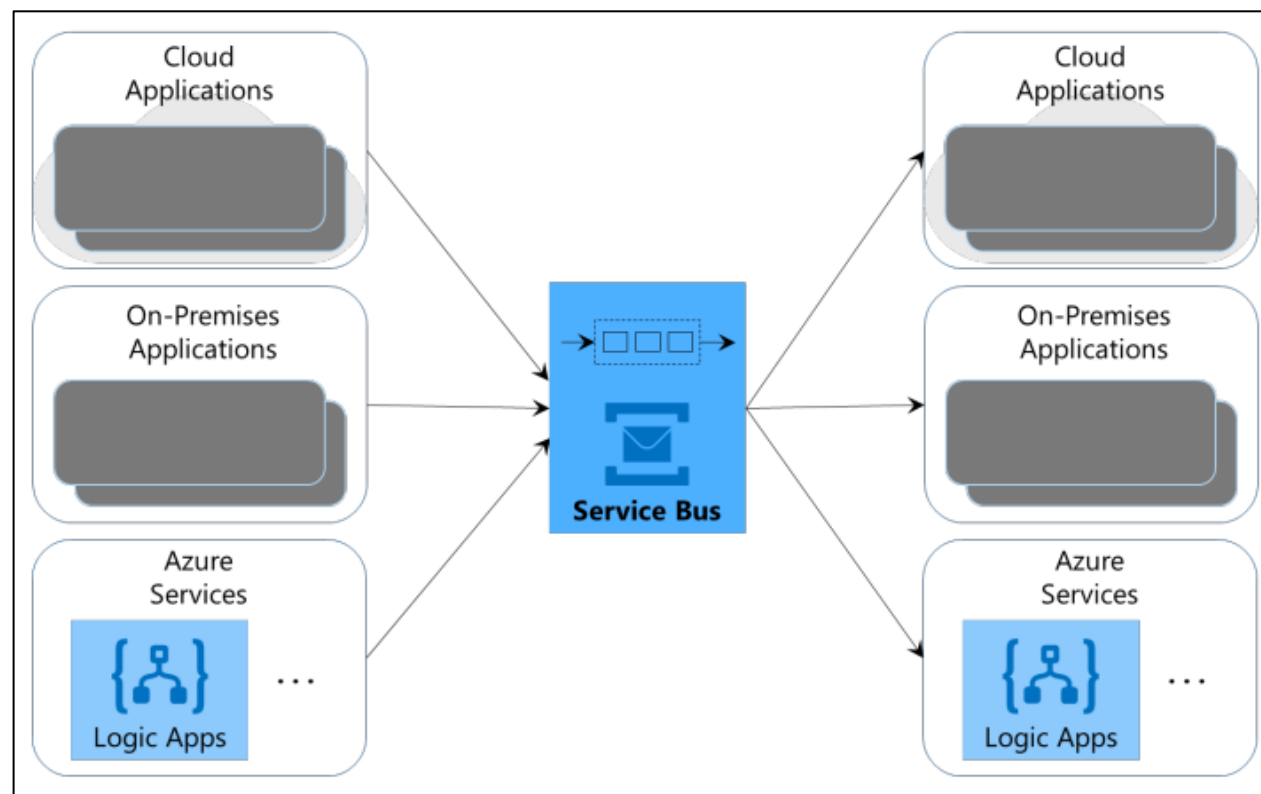



Azure Event Grid

Azure Event Grid notifies receivers when a new message has arrived. This reduces noisy polling for messages.

- Arrival of a new message in Azure Service Bus is detected by Event Grid (which is subscribed to the service bus), which then notifies a Logic App to execute (which acquires the message as its first action)
- Arrival of a new file in Azure Storage is detected by Event Grid (which has subscribed to the storage account), which then notifies a cloud application to process the file
- ...

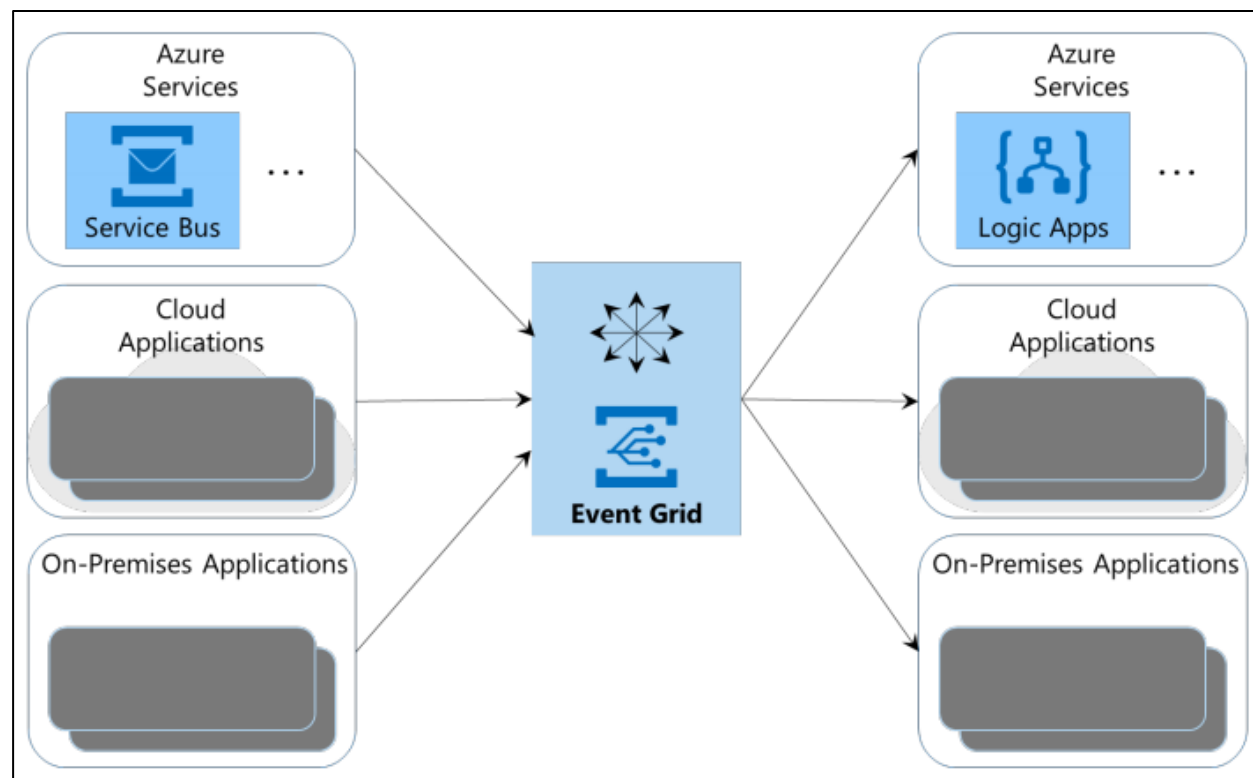

A photograph of a person in a red jacket standing on a rocky cliff overlooking the ocean at sunset. The image is partially obscured by a large red diagonal overlay on the left side of the slide.

Azure iPaaS Patterns

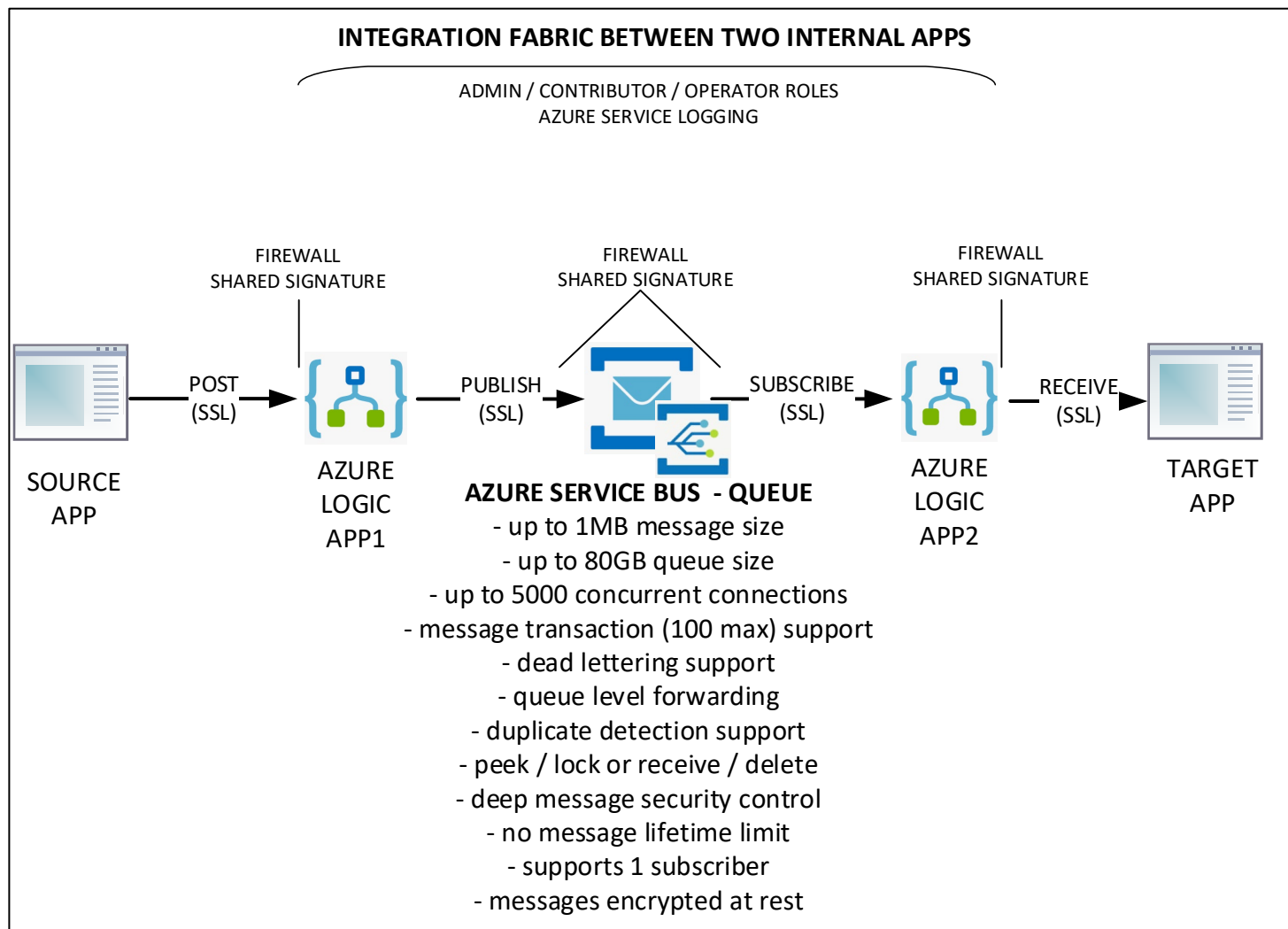



External Apps (B2B)

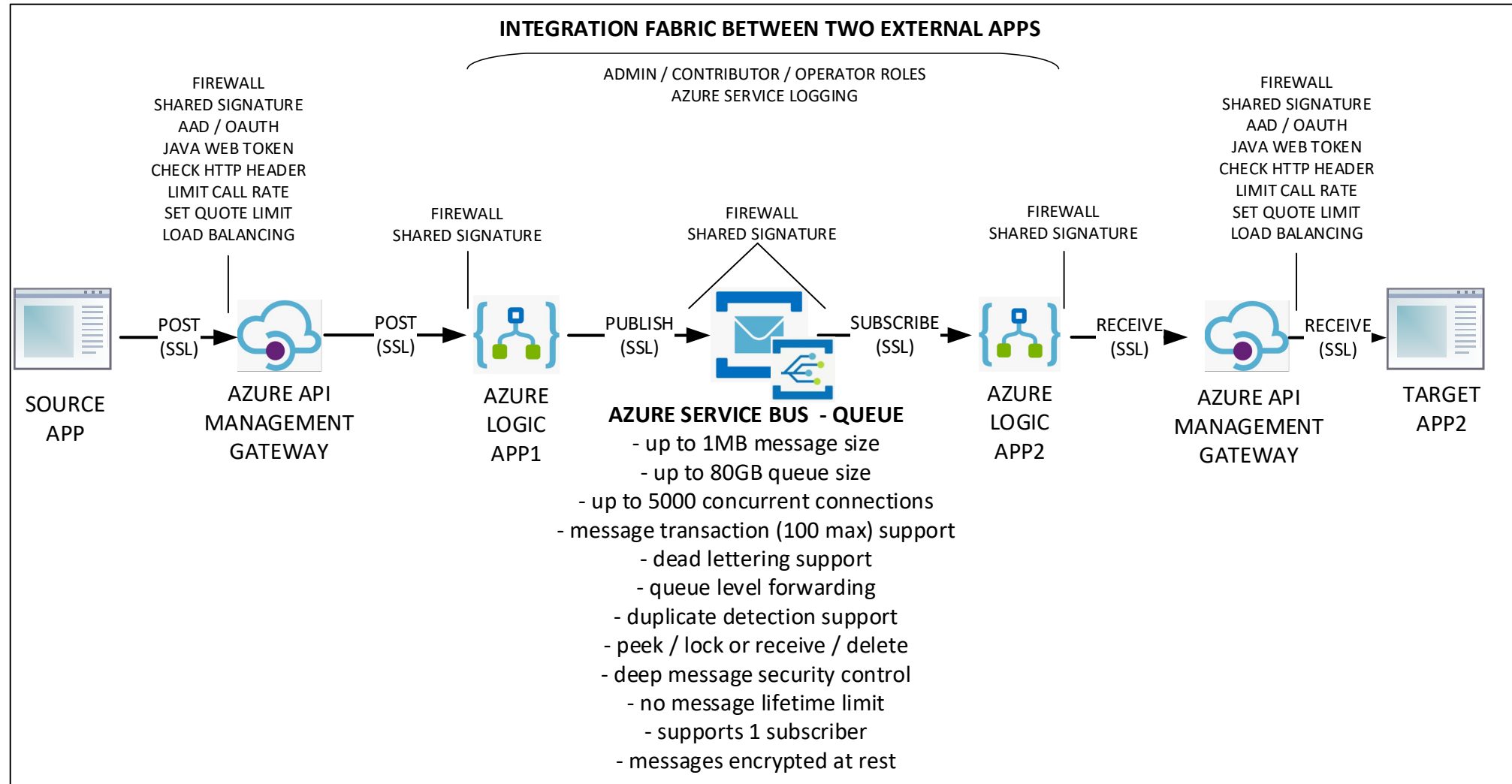

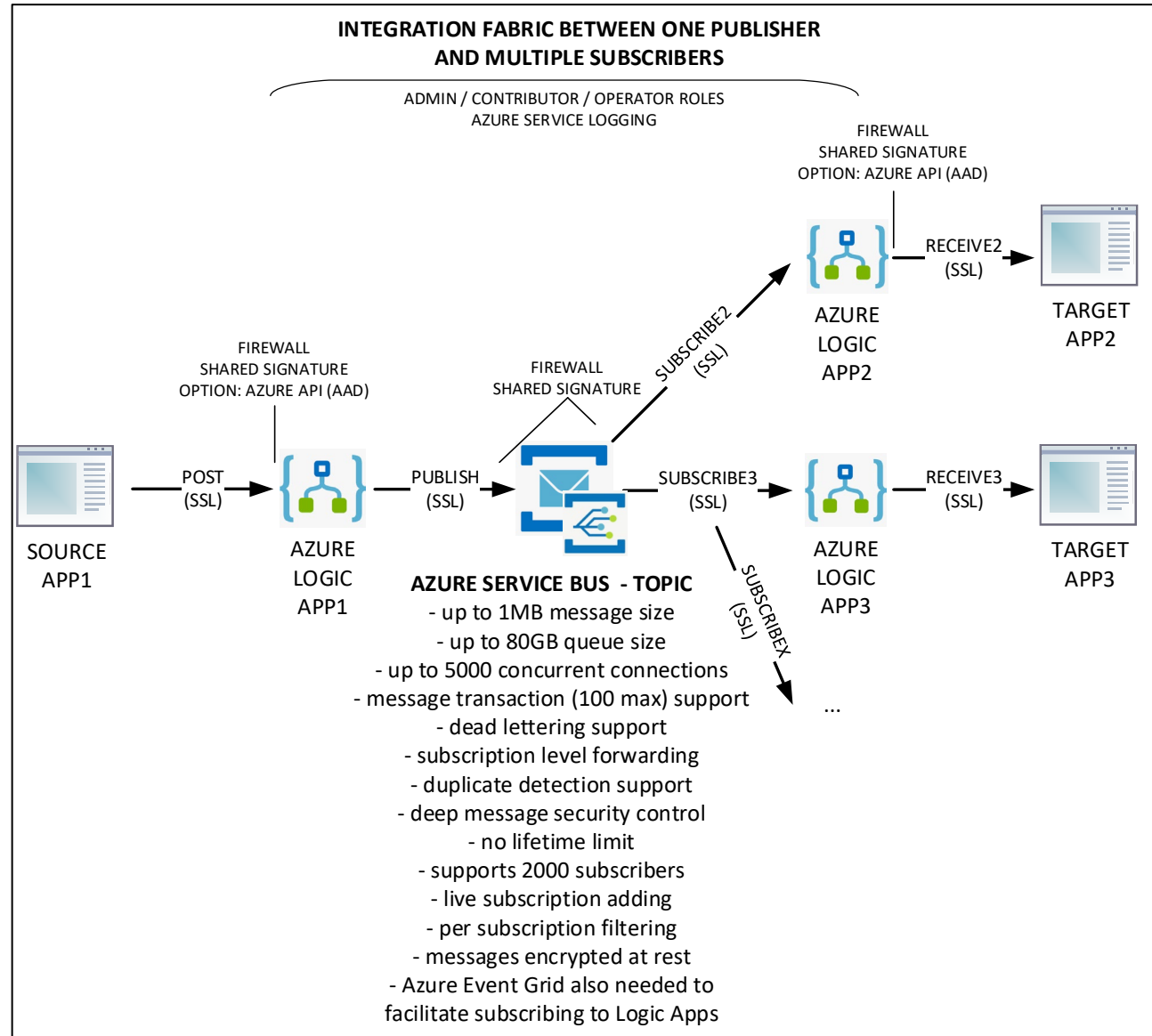



Managed File transfer

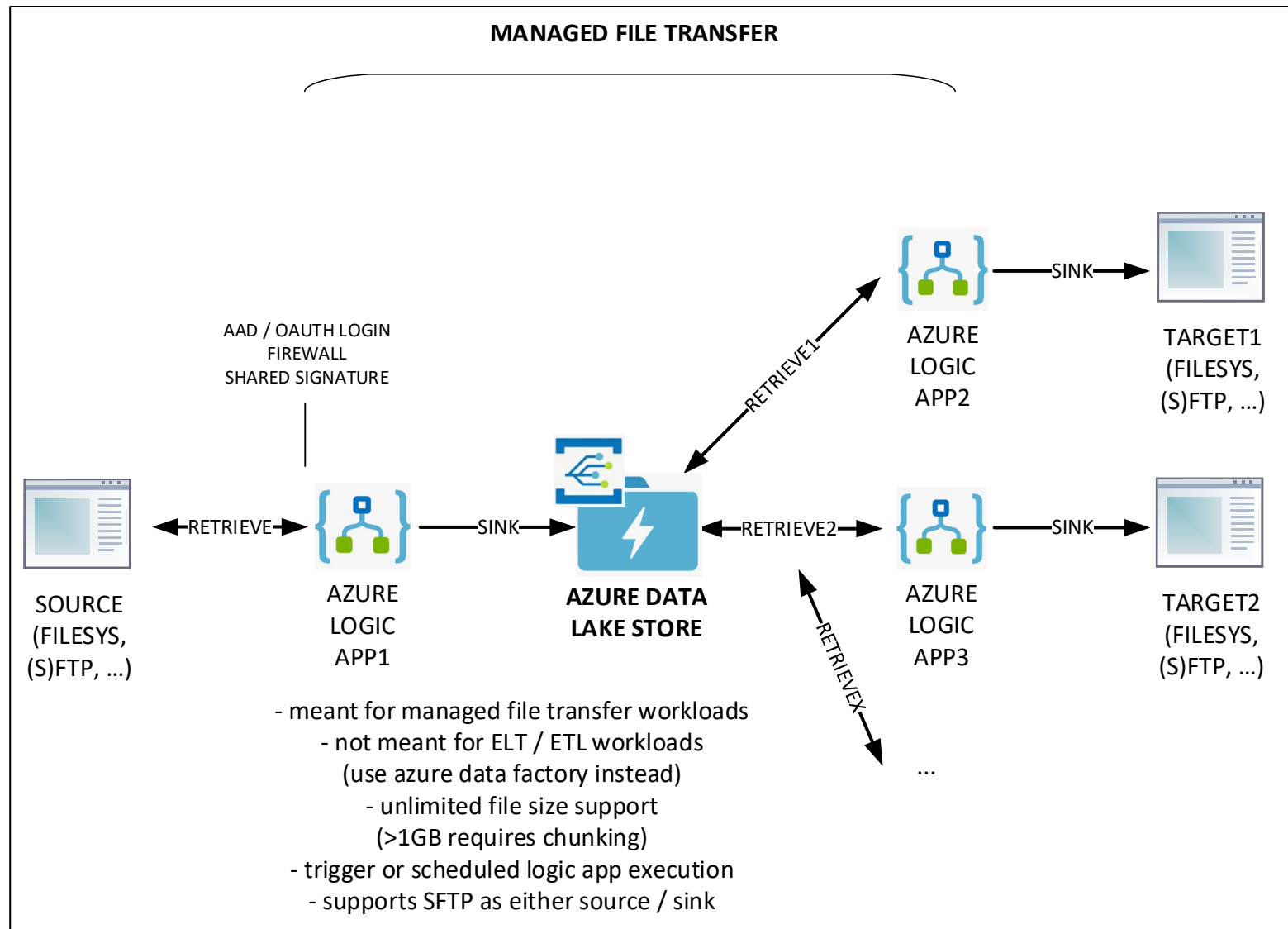

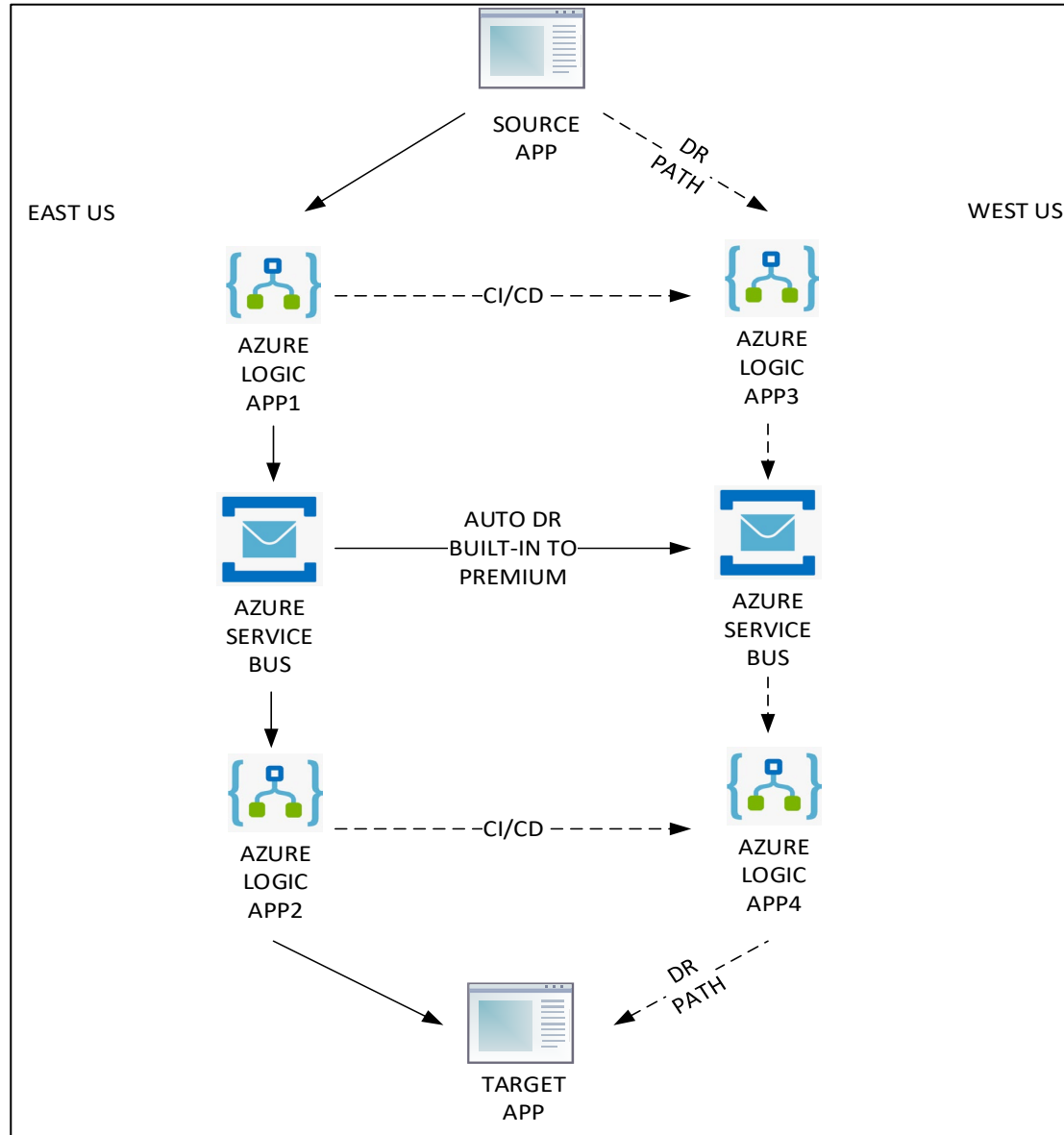



Azure iPaaS Best Practices



Azure iPaaS for IoT

IoT Approach	Azure Services	Use Case
Azure iPaaS	Azure Logic Apps Azure Service Bus	< 10k events per minute Significant transformation required Periodic managed file transfers
Azure IIoT	Azure IoT Hub Azure Event Hub Azure Functions	> 10k events per minute Limited transformation required



Exception Handling

Logic Apps have “retry policy” enabled for actions, by default (4 retries at increasing intervals, up to 45s).

Retry policies can be customized by action / trigger, up to 90 retries / 1 day intervals.

For exception handling, create an “on failure” path in the Logic App workflow.

Group multiple actions together in a “scope”, to consider the actions as a group, from a retry or exception handling perspective.

For custom exception response, use an @result() call in the JSON response, to determine the type of error, then customize the response based on the error type.

Setup alerts from off Azure Log Analytics workspace, to respond to specific exceptions reactively.

Logging

All Logic Apps should have integration with Azure Log Analytics enabled. Azure Log Analytics provides aggregated logging across all Logic Apps, covering correlation ID’s, status, resubmission status, execution time, ...

All Logic Apps will post event details to the central Azure Log Analytics workspace. From this workspace, enterprise wide Logic App details will be queried and can be alerted from.

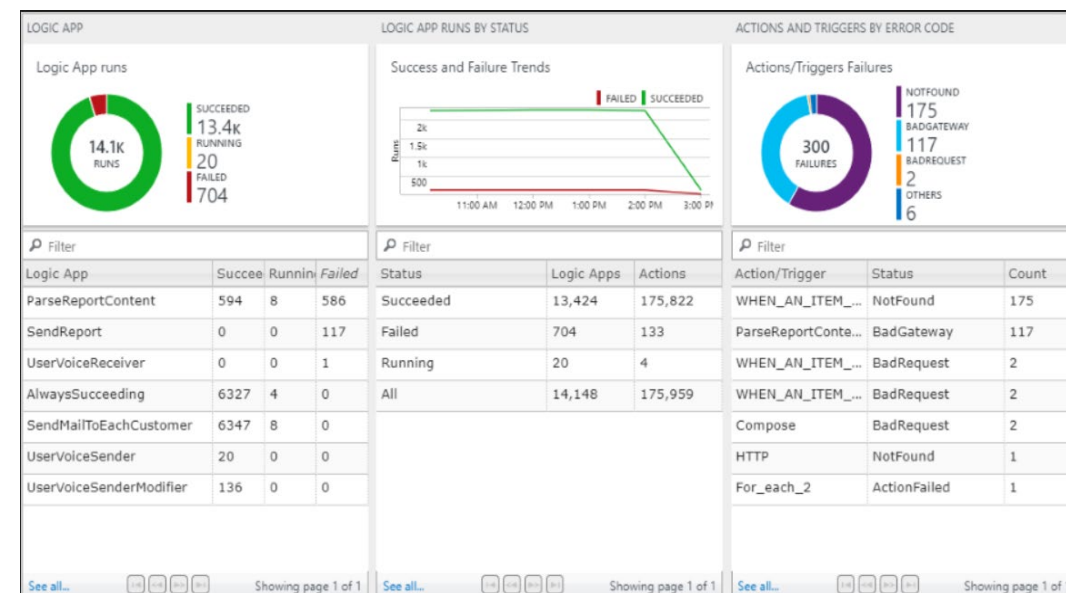



Exception Handling

Azure Service Bus retries sends up to 10 times by default, but this is configurable.

Messages that fail to send after max retries are passed to the Dead Letter Queue. This queue is automatically created with every endpoint. Messages also land in the Dead Letter Queue, if they expire, or no subscription filter match's the message.

An additional process must be implemented (Logic App, Custom Code, Manual), to handle messages that land in the Dead Letter Queue.

For guaranteed message delivery use cases, the Logic App will trigger a “peek and lock” response with Azure Service Bus (rather than “receive and delete”). This way, the message stays in the bus, until the Logic App confirms successful receipt by the client.

Logging

Azure Service Bus should be configured to integrate bus diagnostic logs with the Azure Log Analytics workspace.

All Azure Service Bus queues / topics will consolidate logging into one Azure Log Analytics workspace.

This positions Azure Log Analytics as the one stop shop for end to end event monitoring, from Logic Apps to Service Bus to Logic Apps, across all integrations.

Enables centralized auditing and centralized alert definitions.



Azure iPaaS Adastra Examples



Azure iPaaS Event Map

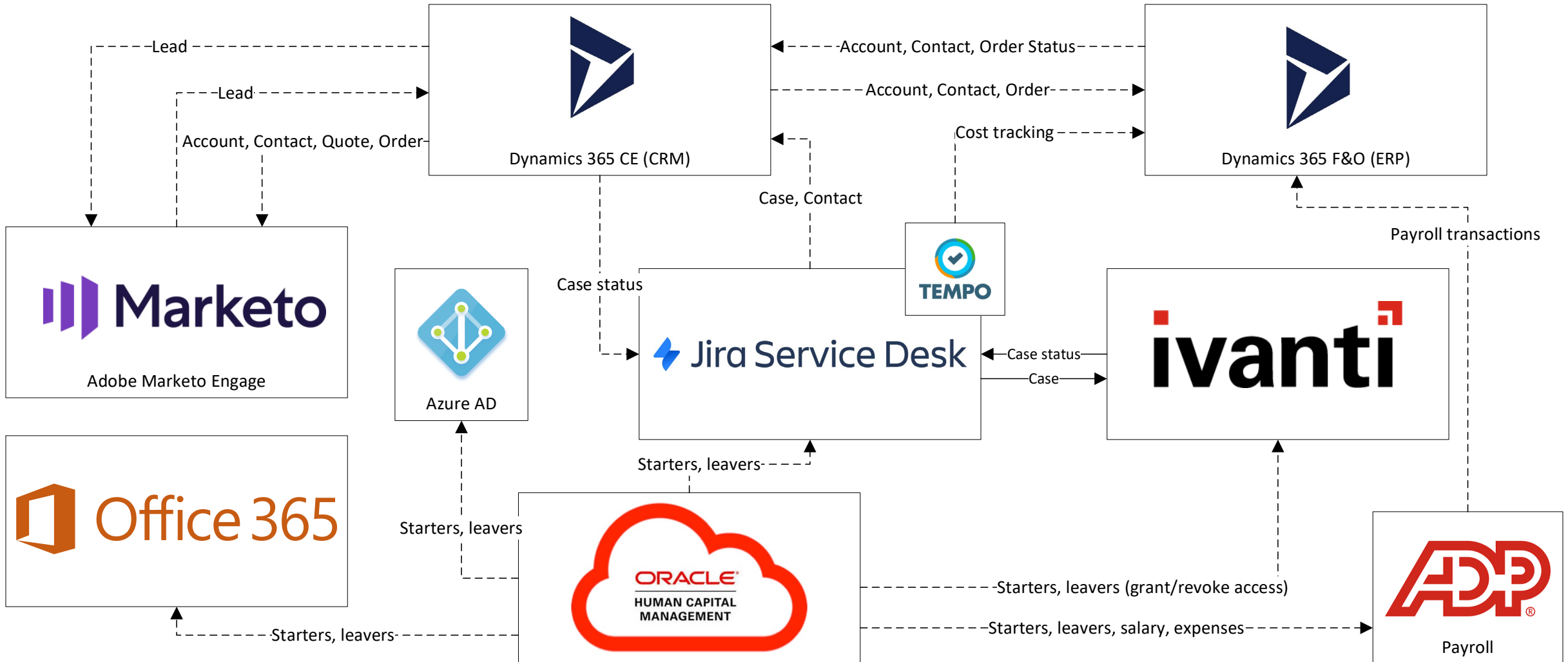



Azure iPaaS Event Map (Marketo / D365)

Scenario	Use Case	Implementation
Lead generation	New lead captured in Marketo	Real-time synchronization of Lead from Marketo to D365
	New lead captured in CRM	Real-time synchronization of Lead from D365 to Marketo
Lead nurturing	Lead Journey progress	Real-time synchronization of Activities from Marketo to D365
Customer nurturing	Customer Journey start	Real-time synchronization of Accounts and supporting information required for the journey (Contacts, Quotes, Orders...) from D365 to Marketo
	Customer Journey progress	Real-time synchronization of Activities from Marketo to D365



Azure iPaaS Event Map (ADP / HCM)

Scenario	Use Case	Implementation
Integration with ADP or similar	Starters, leavers	Real-time integration of Oracle HCM and ADP via REST APIs using Logic Apps. Alternatively use a third-party solution (e.g. Modulus Data)
	Pay run	File exchange between ADP and D365 F&O. Import payroll transactions to General Ledger. Alternatively import detailed payroll transactions to F&O Payroll if used.
Integration with another payroll solution	Starters, leavers	Real-time integration of Oracle HCM and Payroll via REST APIs using Logic Apps if the Payroll solution provides REST APIs or similar. Alternatively a file exchange at a regular schedule (e.g. twice-monthly).
	Pay run	File exchange between ADP and D365 F&O. Import payroll transactions to General Ledger. Alternatively import detailed payroll transactions to F&O Payroll if used. File transformation to be implemented based on the payroll solution specifics.



Azure iPaaS @ Fleet Complete

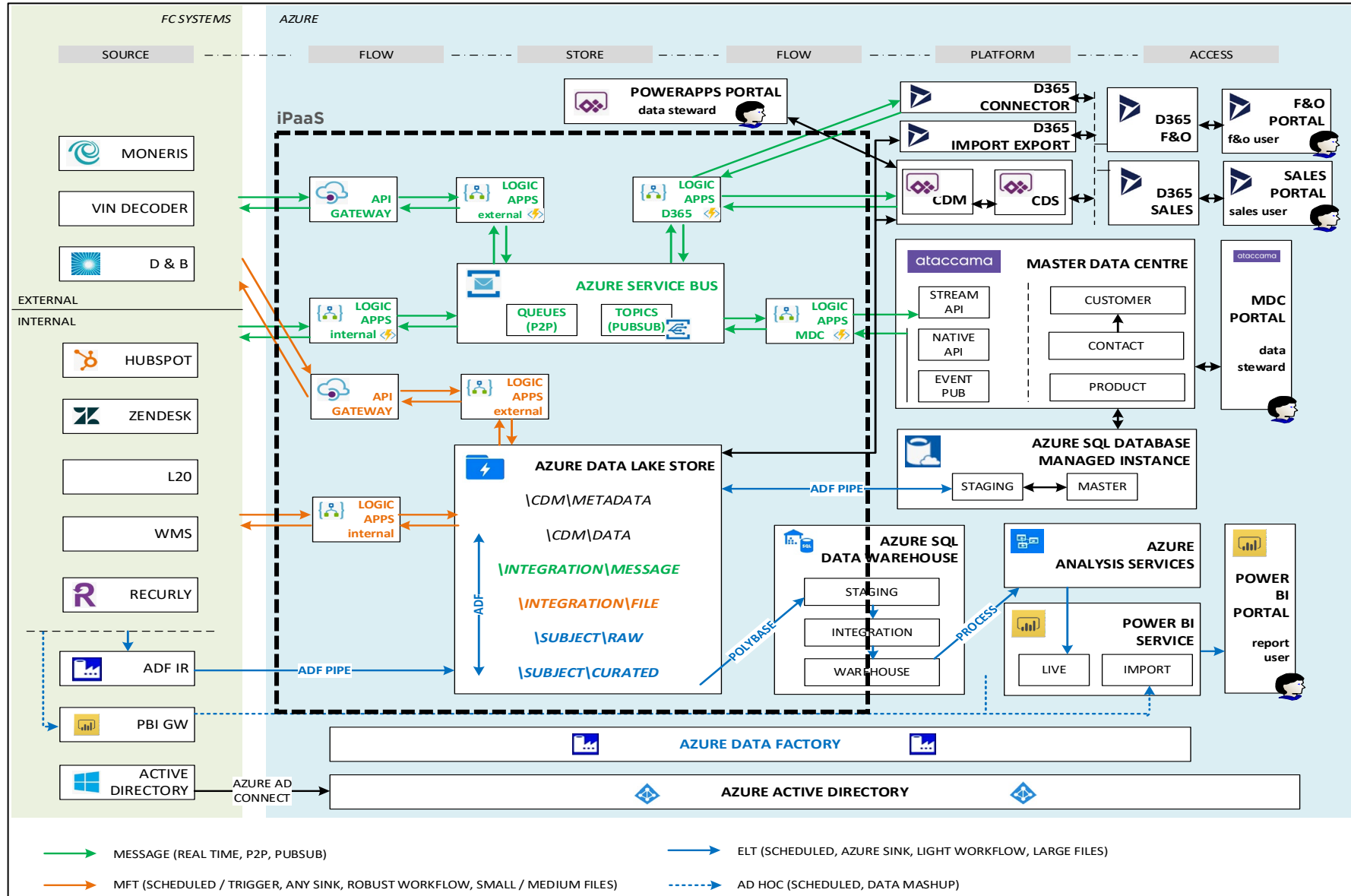



Azure iPaaS Event Map (Apotex Example)

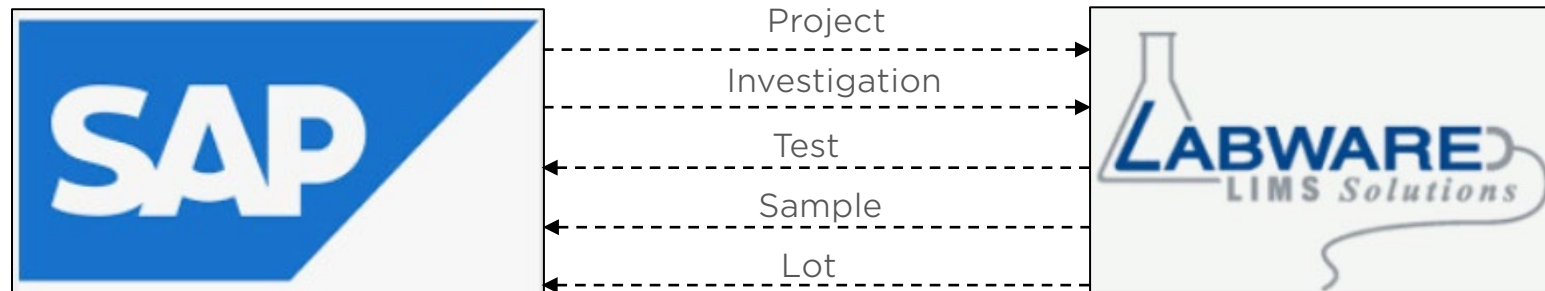



Azure iPaaS Roadmap



Typical iPaaS Roadmap

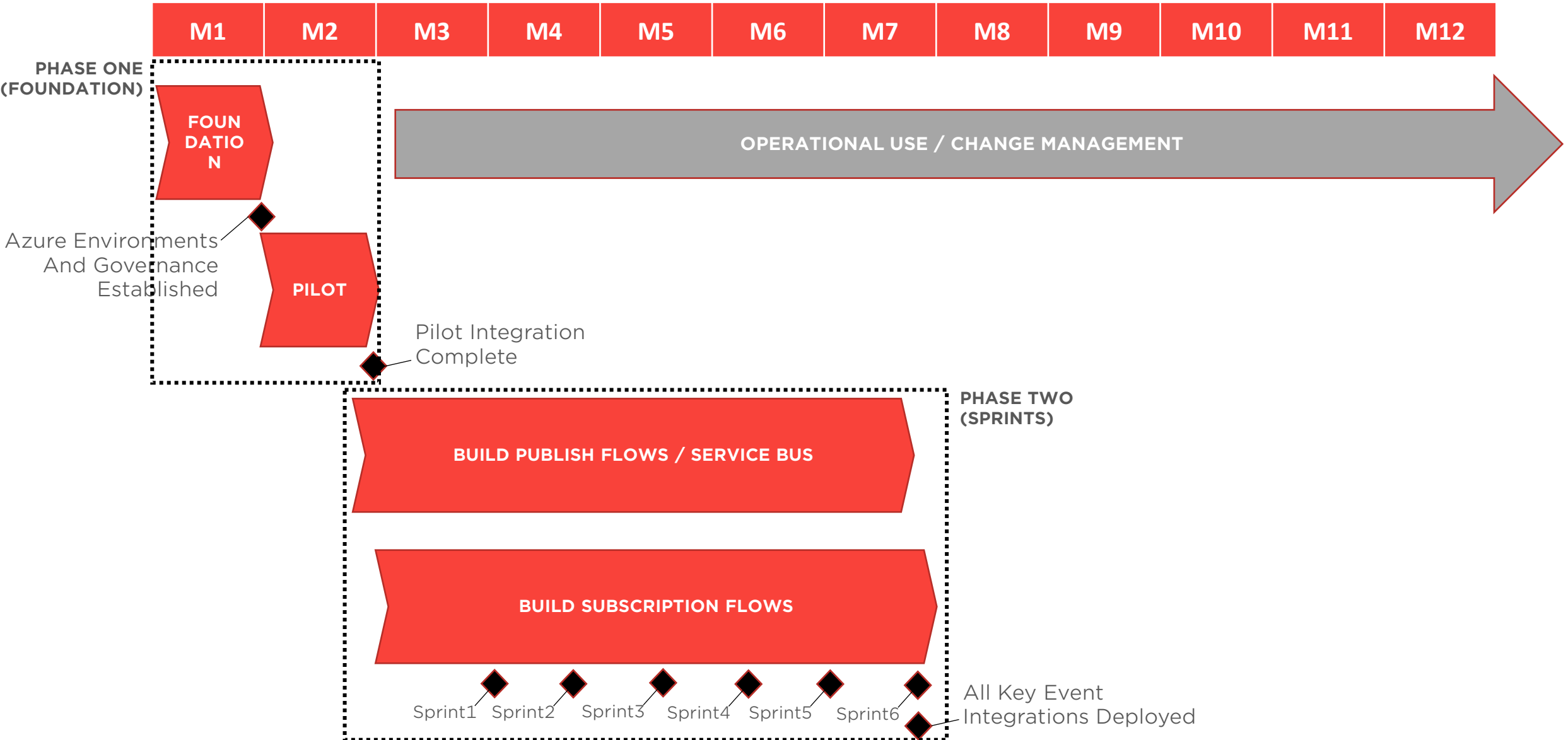



Phase One - Foundation / Pilot

1. Foundation (3w)

- a) Execute Discovery (goals / outcomes, systems, event types, technical requirements, ...)
- b) Define Azure Architecture / Governance (service, network, endpoint, security, retry, exception, monitor, alert, devops)
- c) Define Apotex Event Map / Volumetrics
- d) Provide TCO for Azure Solution
- e) Define Roadmap for Event Adoption
- f) Implement Azure Services
- g) Identify Pilot Use Case

2. Pilot (3w)

- a) Define Business Requirements Specification (event details, schema's, mappings, transformations, ...)
- b) Define Technical Design Specification
- c) Build Queue / Flow / EndPoint Solution
- d) Perform QA / UAT Testing
- e) Deploy to Production

A person in a red jacket stands on a rocky cliff overlooking the ocean at sunset. The scene is split into three diagonal sections: a red-tinted mountain landscape on the left, a person on a cliff in the middle, and a white background on the right.

Azure iPaaS Demo



//ADA STRA

For Questions contact:

Kevin Harmer

Managing Director

kevin.harmer@adastragr.com

m

647-990-2101